



H40+

310mL CARTRIDGE DISPENSER

The new MK H40+ 1-component manual dispenser benefits from a new ergonomic design for faster and easier professional dispensing, compared to the preceding H40 model.



Specifications

- Lightweight: 880g unboxed
- Frame Length: 242mm / 9.5in
- Maximum Thrust: 3kN
- Handle Material: Aluminium
- Frame Material: Steel
- Cartridge Capacity: 310mL
- Standard Colour: Grey/Red
- Mechanical Advantage: 18:1

Dimensions

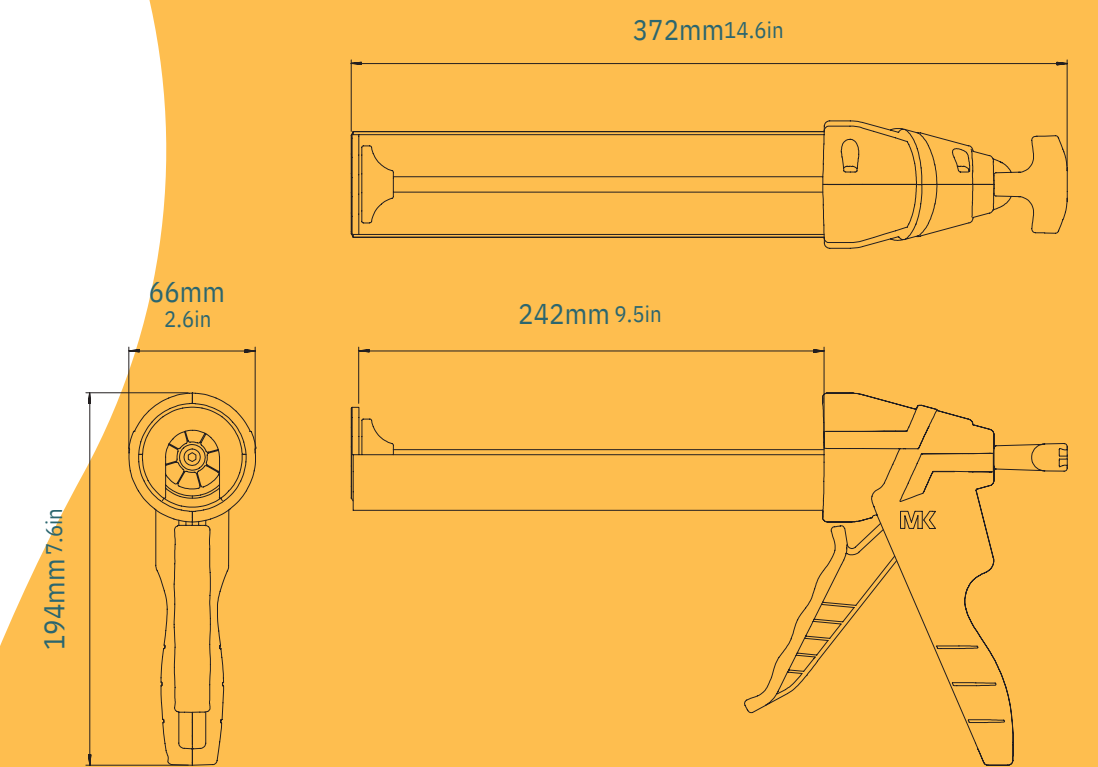

Part number:

DM1K 310-CA-R18-602
DM1K 310-CA-R18-601

Article number:

184014
184013

Packaging:

Single pack (1 per box)
Bulk pack (8 per box)

Features

- Single hand grip dispensing operation
- Ergonomic handle
- Trigger-integrated brake release with anti-drip mechanism
- 360° frame rotation
- U-shaped opening cartridge holder
- 2-Year warranty

Benefits

- Smoother, more precise bead application
- User comfort in all dispensing applications
- One-handed control for fast and precise dispensing
- Uninterrupted handle orientation adjustments to access hard-to-reach areas
- MIXPAC™ New Peeler™ or Mixpeel™ 2-component co-axial and 1-component cartridge fit
- Reliable performance

Applications

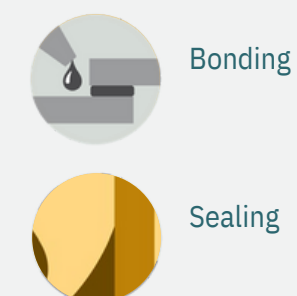

Matching MIXPAC™ cartridges



Compatible cartridges

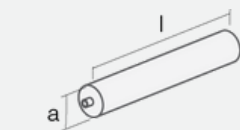

	mm	inch
l	216.0	8.5
a	Ø 50	Ø 1.8

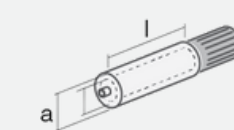

	mm	inch
l	117	4.6
a	Ø 50.0	Ø 1.9

Product by range

